

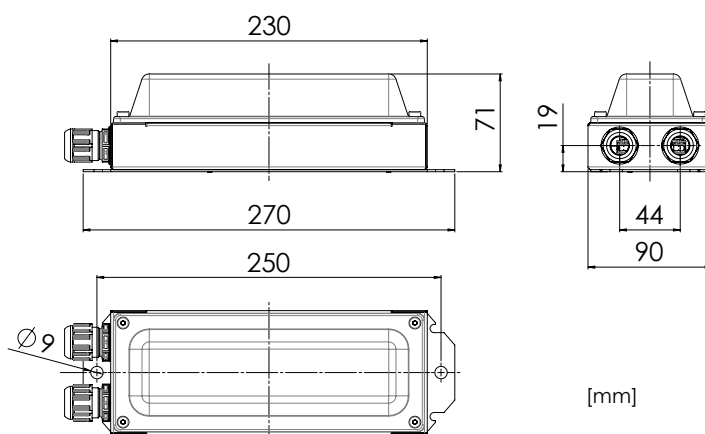

Multipurpose watertight luminaire for decks, stores, engine rooms, IP67

Design	According to rules of maritime classification societies and relevant standards
Housing	Galvanized steel, power coated white (RAL9016)
Cover	Opal or satin polycarbonate, impact-proof, UV resistant
Mounting	Mounting holes, Ø 9 mm
Cable entry	2 cable glands M20, nickel plated brass
Wiring	Flexible wiring, heat resistant up to 105°C
Protection class	IP67
Weight	1.5 kg



Extras

- Stainless steel housing for outdoor marine environment
- Emergency battery back-up
- Different cable glands on request

Part no. 5105009800-xxx

Light source	Cluster LP LED module
Wattage	1x 5,5 W
Equivalent	1x 9 W CFL
CCT (color)	4,500 K
CRI	≥ 80
Voltage	220-240 V AC or 110-120 V AC
Frequency	50-60 Hz

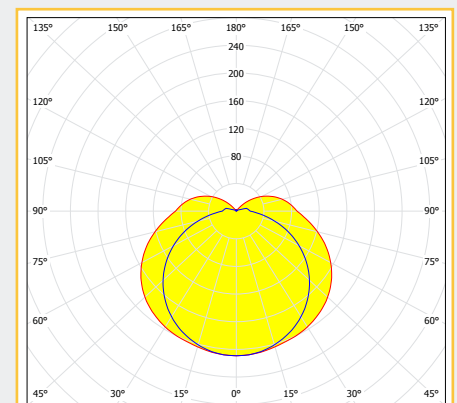

Spare parts

LED module kit	7409001200
LED driver	7103011300
Opal cover	7925000800
Satin cover	7925000900